

3m long racetrack Helmholtz Coil System

— Magnet & PSU

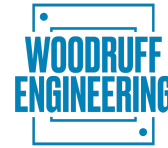

Model WE-KJC · 3 kGauss Pulsed Magnet System for Fusion & High-Energy Physics Applications
FAT & SAT COMPLETE FAT & SAT complete · System in production use · Available for scale production · 14.24 kA / 3 kGauss field validated

· Rev 02 · 2026-03-09

Production-Validated High-Field Racetrack Helmholtz Architecture

The Woodruff Engineering 4m Helmholtz Coil System is a production-validated, high-current pulsed magnet assembly engineered for laser fusion and high-energy physics applications requiring precise axial magnetic field control across extended working volumes. Generating 3 kGauss (0.3 Tesla) across a 2 meter × 0.3 meter uniformity zone, the system comprises two water-cooled racetrack-shaped coils (3 m × 0.5 m × 0.6 m each) separated by 0.55 meters to achieve the Helmholtz geometry condition for optimal field uniformity along the extended axial dimension. Having successfully completed both Factory Acceptance Testing (FAT) and Site Acceptance Testing (SAT), the system transitioned to active production use where it provides reliable high-field generation for experimental campaigns requiring sustained pulsed magnetic fields with precisely controlled temporal profiles and spatial uniformity.

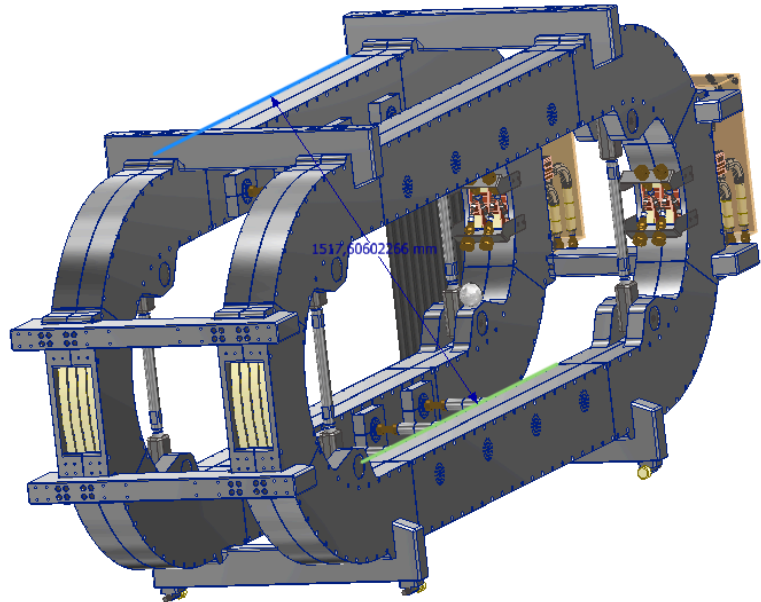

Megampere-Turn Capability with Supercapacitor-Fed IGBT Power Supply

Nominal operation requires 14.24 kA per coil, corresponding to 0.285 MA-turns total magnetomotive force, delivered at a 5% duty cycle (18 seconds energized, 9.5 minutes off) to maintain thermal equilibrium in the water-cooled copper windings while supporting repetitive experimental shot schedules. The dedicated IGBT buck-converter power supply, fed from supercapacitor energy storage banks charged by TDK Lambda AC-DC converters, provides precise current regulation with programmable waveform shaping for experimental protocols requiring controlled field ramps, extended flat-top phases, and gradual field decay to minimize eddy current heating in surrounding conductive structures. Peak capability extends to 16 kA for 100-millisecond flat-top pulses—enabling transient field generation at 110% nominal for short-duration experiments or diagnostic calibration shots—while the supercapacitor architecture eliminates line-voltage sag concerns and provides clean, ripple-free current delivery isolated from facility power quality variations.



Comprehensive Protection and Programmable Control Platform

Protective systems integrate multi-layer fault response: an SCR-based overcurrent crowbar triggers at 3.2 kA to rapidly commutate coil current into a low-impedance dump path on detection of insulation breakdown or turn-to-turn shorts, preventing catastrophic winding damage during fault conditions. A fail-safe normally-closed capacitor dump relay provides independent energy bleed capability, ensuring stored energy dissipation even during control system failures or power loss, while overvoltage protection (OVP) and overcurrent protection (OCP) circuits on all TDK Lambda charging modules prevent damage to supercapacitor banks from charging system faults. The Portenta M4/Linux control platform with GIGA touchscreen interface provides local operator control and real-time telemetry display, while UDP Ethernet connectivity enables remote experimental sequencing with fully programmable current waveform profiles—ramp rates, flat-top duration, and decay characteristics—allowing integration with facility shot-control systems.

COMSOL simulations

Magnetic modeling

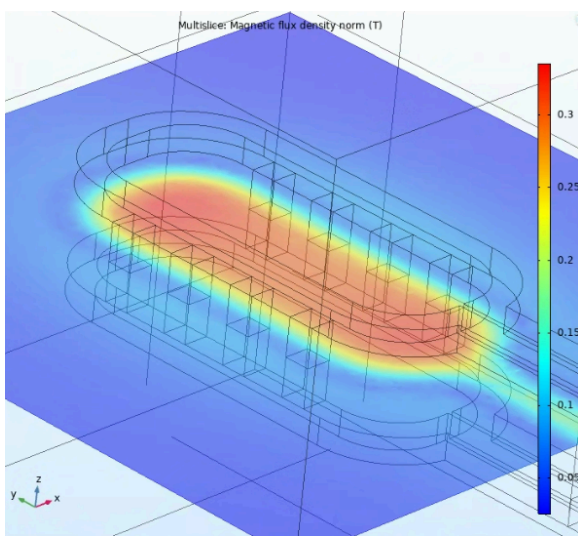

Stress analysis

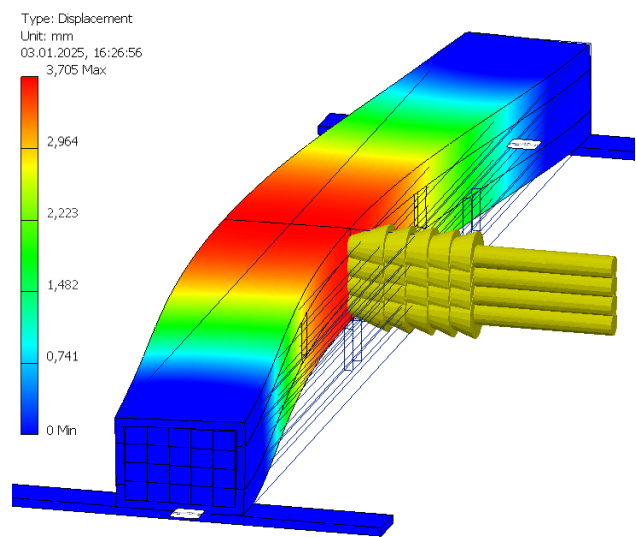

Thermal modeling

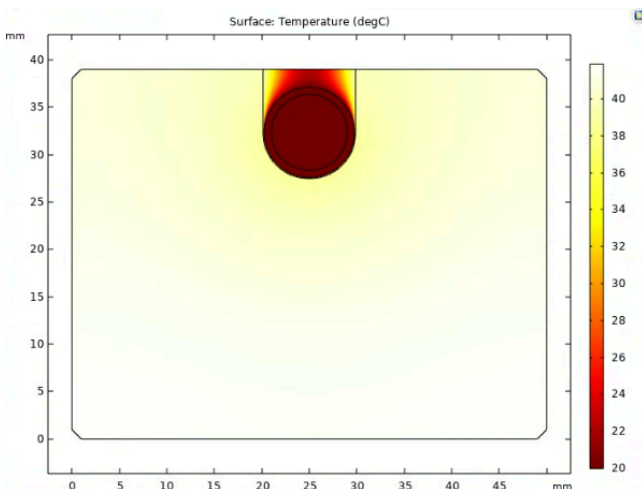

Stress analysis

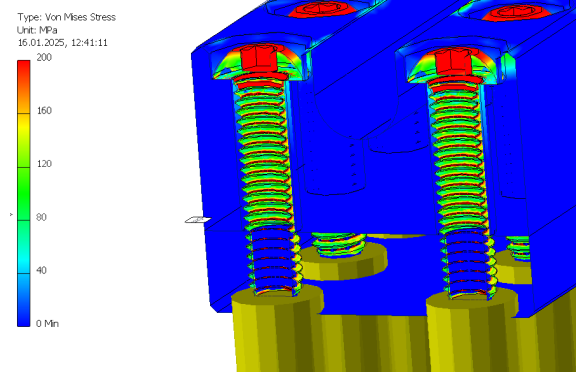

Woodruff Engineering Inc.

1003 Midtown Calle Central, Santa Fe, NM 87505, USA ·

woodruffeng.com sales@woodruffeng.com

Production datasheet reviewed & accepted requirements.

© 2026 Woodruff Engineering Inc. All rights reserved.

RACETRACK HELMHOLTZ COIL SYSTEM

Production-Validated High-Current Pulsed Magnet Assembly

3 kGauss @ 14.24 kA • 0.285 MA·turns • 2m × 0.3m Uniformity Volume • FAT/SAT Complete • Active Production Use

SYSTEM OVERVIEW

System Type	Racetrack Helmholtz Coil Pair <i>Two coils in Helmholtz configuration</i>
Primary Application	Laser fusion & high-energy physics <i>Extended axial field uniformity for elongated experiments</i>
Production Status	FAT/SAT Complete - Active Production Use <i>Factory and Site Acceptance Testing validated</i>
Central Magnetic Field	3 kGauss (0.3 Tesla) nominal (4kGauss reached) <i>At 14.24 kA per coil (0.285 MA·turns total)</i>
Design Peak Field Capability	3.37 kGauss (0.337 T) <i>At 16 kA peak current for 100 ms flat-top</i>
Field Uniformity Volume	2.0 m × 0.3 m (axial × radial) <i>Extended uniformity region for laser fusion experiments</i>
Duty Cycle	5% (18 s on / 9.5 min off) <i>Thermal management enforced in software</i>
Power Supply Architecture	Supercapacitor-fed IGBT buck converter <i>TDK Lambda AC-DC chargers feeding supercapacitor banks</i>
Control System	Portenta M4/Linux + GIGA touchscreen <i>UDP Ethernet remote control with programmable waveforms</i>

COIL SPECIFICATIONS (GEOMETRY & DIMENSIONS)

Coil Geometry	Racetrack (elongated rectangular) <i>Two identical coils in Helmholtz pair arrangement</i>
----------------------	---

Overall Coil Dimensions	3.0 m × 0.50 m × 0.60 m per coil <i>Length × Height × Depth (axial coil dimension)</i>
Axial Coil Length	0.20 m (200 mm) per coil <i>Coil depth along magnetic field axis</i>
Coil Separation	0.55 m (550 mm) <i>Helmholtz spacing validated at SAT</i>
Conductor Type	Water-cooled copper inside aluminum winding <i>Square or rectangular copper with internal cooling channels</i>
Number of Turns	100 turns per coil
Winding Configuration	Multi-layer pancake winding <i>Optimized for thermal management and field uniformity</i>
Insulation Class	Class H (180°C) <i>High-temperature epoxy or Kapton insulation</i>
Coil Weight	~3000 kg per coil (estimated) <i>Including aluminum, insulation, and cooling manifolds</i>
Mounting	Rigid support structure <i>Maintains 0.55 m separation under Lorentz forces</i>

MAGNETIC FIELD PERFORMANCE

Central Field (Nominal)	3.0 kGauss (0.30 Tesla) <i>At 14.24 kA per coil (0.285 MA·turns)</i>
Central Field (Peak)	3.37 kGauss (0.337 Tesla) <i>At 16 kA per coil (0.32 MA·turns)</i>
Field Calculation	$B = 4 \times 0.2 \times 0.32 / (0.5 \times 1.518)$ <i>Helmholtz formula: $B \propto NI / (\text{coil radius} \times \text{geometry factor})$</i>
Field Uniformity Region	2.0 m × 0.3 m (axial × radial) <i>Extended axial uniformity for laser fusion experiments</i>

Axial Uniformity	±5% over 2.0 m length (estimated) <i>Along central axis within uniformity volume</i>
Radial Uniformity	±3% over Ø300 mm (estimated) <i>Within central cross-section</i>
Field Orientation	Axial (parallel to 3 m dimension) <i>Aligned with long axis of racetrack geometry</i>
Magnetomotive Force	0.285 MA·turns @ 14.24 kA <i>20 turns × 14.24 kA = 284,800 A·turns</i>
Field Scaling	Linear with current <i>(14.24/16) × 3.37 kG = 3.0 kG validation</i>

POWER SUPPLY SPECIFICATIONS (IGBT BUCK CONVERTER)

Topology	IGBT buck converter (step-down) <i>Supercapacitor-fed; minimizes IGBT count and cost</i>
Peak Output Current	16,000 A per coil <i>1s flat-top capability; FAT validated</i>
Nominal Output Current	14.24 kA per coil <i>0.285 MA·turns required for 3 kGauss field</i>
IGBT Module Current Rating	3.0 kA nominal / 3.2 kA maximum <i>SCR crowbar trips at 3.2 kA overshoot per IGBT module</i>
Number of IGBT Modules	6 modules in parallel per coil <i>16 kA / 3 kA per module ≈ 5-6 parallel modules</i>
Current Ripple	<1% RMS <i>Measured and validated during FAT</i>
PWM Switching Frequency	100 Hz – 1 kHz <i>Low-frequency switching; verified operating range</i>
Input Source	Supercapacitor bank <i>Fed from TDK Lambda AC-DC chargers</i>

Output Voltage Range	0 – 300 V (estimated) <i>Sufficient for coil inductance and resistance drop</i>
Coil Power Range	500 – 1000 kW per coil <i>Target 800 kW nominal operation</i>

CHARGING SYSTEM (SUPERCAPACITORS & TDK LAMBDA CHARGERS)

Charger Type	TDK Lambda AC-DC power supply <i>Industrial-grade high-power rectifier</i>
Charging Power (per coil)	30 – 40 kW per coil <i>Total 45 kW for both coils combined</i>
Charger Output Voltage	285 V maximum <i>Voltage steps <10 V resolution</i>
Charger Output Current	50 A maximum <i>Per charger module</i>
Charger Control Interface	UART serial control <i>Programmable voltage setpoint and current limit</i>
Input Power	3-phase 208 VAC <i>Industrial mains power</i>
Input Protection	OVP and OCP on all charger rails <i>Overvoltage and overcurrent protection</i>
Supercapacitor Bank Voltage	~300 V (estimated) <i>Matches charger output and IGBT input rating</i>
Supercapacitor Capacitance	See separate spec sheet on the PSU <i>Sufficient for $800\text{ kW} \times 18\text{ s} = 14.4\text{ MJ}$ per coil</i>
Charge Time	9.5 minutes typical <i>Off-time between pulses for supercapacitor recharge</i>

CONTROL SYSTEM (PORTENTA M4 / LINUX)

Control Platform	Portenta M4 / Linux dual-core <i>Embedded ARM processor with Linux OS</i>
Local Interface	GIGA touchscreen display <i>Local operator control and telemetry display</i>
Remote Control Interface	UDP Ethernet (PORTENTA EXT) <i>Remote experimental sequencing and waveform programming</i>
Waveform Programming	Ramp / flat-top / ramp-down <i>Polynomial profile; software configurable per pulse</i>
Flat-Top Duration	1s programmable (default) <i>18 second hard operation limit enforced in software</i>
Maximum On-Time	18 seconds <i>Software-enforced thermal protection limit</i>
Minimum Off-Time	9.5 minutes <i>Required for supercapacitor recharge and coil cooling</i>
Current Monitoring	Real-time; ± 24 V analog probe <i>Outputs 0 V when IGBT fiber disconnected/low</i>
Voltage Monitoring	Real-time analog voltmeter <i>MEAS VOLTAGE output; warning lamp active >50 V</i>
External Enable Interlock	EXT ENABLE hardware input <i>IGBT output gated by hardware interlock signal</i>
Inductance Estimation	$L = V / (di/dt)$ computed on first pulse <i>Includes mutual coupling between coils</i>

PROTECTION AND SAFETY SYSTEMS

Overcurrent Protection (IGBT)	SCR crowbar at 3200 A per module <i>Triggers fuse-blow; SCR TRIG signal raised on OCP event</i>
Overvoltage Protection	OVP on all charger & PSU rails <i>Hardware-verified overvoltage shutdown</i>

Overcurrent Protection (Chargers)	OCP on all charging circuits <i>Prevents supercapacitor overcharge or fault current</i>
Back-EMF Protection	Reverse-biased diodes on IGBT outputs <i>Recovery characteristics selected for buck topology</i>
Capacitor Dump Relay	Fail-safe normally-closed dump relay <i>17.65 A dump current (300 V / 17 Ω resistor)</i>
Dump Activation	Automatic on power loss <i>NC relay opens charging path, engages dump resistor</i>
Dump Time Constant	≤ 16 minutes to 16% voltage <i>Verified at 100 V initial charge; RC decay</i>
Maximum Dump Temperature	50°C enclosure temperature <i>Fan-cooled; 95% energy discharged within thermal limit</i>
Isolation Resistance	≥ 1 M Ω at 500 V test <i>All HV rails to enclosure; IEC-compliant</i>
Ground Continuity	< 1 Ω to mains earth <i>Verified on all mains connections (1P grounding)</i>
IGBT Maximum Temperature	95°C junction temperature <i>Thermal shutdown on IGBT overtemperature</i>

COOLING SYSTEM

Coil Cooling Method	Active liquid chiller (customer-supplied) <i>External chilled water loop for coil windings</i>
Coolant Type	Water or water-glycol mix <i>Facility-provided cooling fluid</i>
Thermal Management Strategy	5% duty cycle (18 s on / 9.5 min off) <i>Software-enforced to maintain thermal equilibrium</i>
Coil Power Dissipation	500 – 1000 kW during pulse <i>Target 800 kW nominal; I^2R losses in copper</i>

Cooling Capacity Required	~50 kW average (with 5% duty cycle) <i>800 kW × 5% = 40 kW average + safety margin</i>
Coil Temperature Rise	Managed by duty cycle enforcement <i>18 s pulse limited to prevent insulation damage</i>
IGBT Cooling	Water-cooled cold plates or air-cooled heatsinks <i>Separate from coil cooling circuit</i>
Dump Resistor Cooling	Fan-cooled enclosure <i>95% energy dissipation within 50°C thermal limit</i>

PERFORMANCE SPECIFICATIONS

Rise Time (Current)	Software programmable <i>Polynomial ramp profile; milliseconds to seconds</i>
Flat-Top Duration	100 ms typical (programmable) <i>Constant-current regulation during flat-top phase</i>
Fall Time (Current)	Software programmable <i>Controlled ramp-down to minimize eddy currents</i>
Current Regulation Accuracy	<1% ripple during flat-top <i>PWM regulation with feedback control</i>
Field Stability	Proportional to current stability <i>$B \propto I$ linear relationship</i>
Pulse Repetition Rate	Maximum 1 pulse per 10 minutes <i>5% duty cycle: 18 s on + 9.5 min off</i>
Energy Efficiency	~90% (estimated) <i>IGBT switching losses + coil resistance + buswork</i>
Buswork Losses	1 – 5% of load energy <i>Calculated and documented</i>

ELECTRICAL SPECIFICATIONS SUMMARY

Nominal Operating Current	14.24 kA per coil <i>Both coils in series electrical circuit</i>
Peak Operating Current	16 kA per coil <i>100 ms flat-top validated at FAT</i>
Total Magnetomotive Force	0.285 MA·turns @ 14.24 kA <i>20 turns × 14.24 kA per coil × 2 coils</i>
Coil Inductance	Computed via $L = V / (di/dt)$ <i>First-pulse measurement including mutual coupling</i>
Coil Resistance	Low (milliohms range) <i>Copper winding resistance at operating temperature</i>
Operating Voltage	0 – 300 V (estimated) <i>Buck converter output to overcome coil impedance</i>

KEY FEATURES

Extended Axial Uniformity via Racetrack Geometry: The racetrack coil design (3 m × 1.5 m elongated rectangular shape) delivers 2 meter axial field uniformity—far exceeding what conventional circular Helmholtz pairs can achieve—enabling laser fusion experiments where plasma confinement, beam propagation, or diagnostic access require extended uniform-field regions along the target chamber axis. Helmholtz spacing (0.55 m separation) optimizes the trade-off between field strength and uniformity across the 2 m × 0.3 m working volume, validated through Site Acceptance Testing and confirmed in active production use.

Supercapacitor-Fed IGBT Buck Converter for Clean Current Delivery: The supercapacitor energy storage architecture isolates the high-current magnet system from facility power quality variations—eliminating line-voltage sag, harmonic distortion, and transient spikes that would otherwise destabilize magnetic field uniformity during precision experiments. IGBT buck converter topology provides precise PWM current regulation with <1% ripple while minimizing semiconductor count and cost compared to full-bridge topologies, with TDK Lambda AC-DC chargers recharging the supercapacitor banks during the 9.5 minute off-period between experimental shots. The 100 Hz – 1 kHz PWM switching frequency balances control bandwidth against switching losses, validated during Factory Acceptance Testing for stable flat-top current regulation across the full 14.24 – 16 kA operating range.

Programmable Waveform Control with Portenta M4/Linux Platform: Polynomial current profile generation enables arbitrary ramp-up, flat-top, and ramp-down waveforms software-configurable on a per-pulse basis—critical for laser fusion experiments requiring synchronized magnetic field

application with precise temporal coordination to nanosecond-scale laser firing, plasma formation timing, or diagnostic window gating. The Portenta M4/Linux dual-core embedded platform provides local touchscreen control via GIGA display for operator setup and real-time telemetry monitoring, while UDP Ethernet remote control integrates with facility shot-control systems for automated experimental sequencing where magnetic field profiles must adapt dynamically to changing experimental protocols or diagnostic requirements across multi-shot campaigns.

Multi-Layer Protection with Fail-Safe Dump Architecture: SCR crowbar protection on each IGBT module triggers at 3.2 kA overcurrent—rapidly commutating coil current into a low-impedance fault path to prevent catastrophic winding damage from turn-to-turn shorts or insulation breakdown during high-field operation. Independent fail-safe normally-closed capacitor dump relay provides passive energy bleed (17.65 A through 17 Ω resistor) that activates automatically on power loss or control system fault, dissipating 95% of stored supercapacitor energy within the 50°C thermal limit of the fan-cooled dump enclosure. Back-EMF diodes protect IGBT modules from inductive voltage spikes during rapid current interruption, while the external enable interlock (EXT ENABLE) gates all IGBT firing—enabling integration with facility safety systems that inhibit magnet operation during personnel access or experimental anomalies.

Production-Validated System with FAT/SAT Documentation: Having completed Factory Acceptance Testing and Site Acceptance Testing with documented validation of all performance parameters—peak current capability (16 kA), field uniformity (2 m \times 0.3 m volume), coil separation (0.55 m Helmholtz spacing), protection system response (SCR crowbar, dump relay, thermal limits), and control interface functionality (UDP Ethernet, waveform programming, interlocks)—the system transitioned to active production use where operational experience confirms long-term reliability and validates the 5% duty cycle thermal management strategy (18 s on / 9.5 min off) for sustained experimental campaigns. Complete technical documentation (WE-KJC-DS-001) includes field derivation formulas, protection system schematics, control interface protocols, and commissioning test reports for future installations or system upgrades.

Supercapacitor Power Supplies

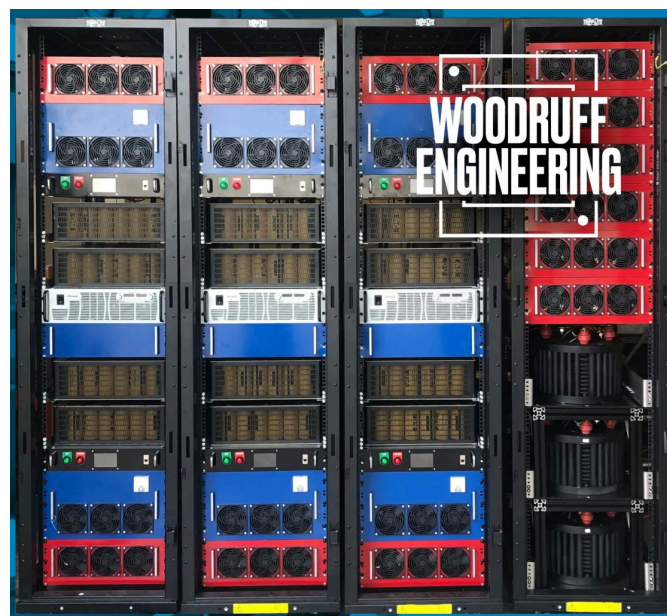

See our [website](#) for more information

Woodruff Engineering Inc.

1003 Midtown Calle Central, Santa Fe, NM 87505, USA ·

woodruffeng.com sales@woodruffeng.com

Production datasheet reviewed & accepted requirements.

© 2026 Woodruff Engineering Inc. All rights reserved.

HIGH-CURRENT HELMHOLTZ COIL SYSTEMS — Product Variants

Water-Cooled Aluminum Construction • Racetrack & Circular Geometries • IGBT Buck Converter • Supercapacitor Energy Storage

MODEL	GEOMETRY	COIL SIZE	FIELD	CURRENT	POWER	UNIFORMITYVOLUME	LEADTIME
WE-HC-300-1KG	CircularHelmholtz	Ø300 mm 150 mm sep	1 kG(0.1 T)	2 kA	50 kW	Ø100 mmsphere	16 wks
WE-HC-500-2KG	CircularHelmholtz	Ø500 mm 250 mm sep	2 kG(0.2 T)	5 kA	150 kW	Ø150 mmsphere	18 wks
WE-HC-1000-3KG	CircularHelmholtz	Ø1000 mm 500 mm sep	3 kG(0.3 T)	10 kA	500 kW	Ø300 mmsphere	22 wks
WE-RT-2000-2KG	RacetrackHelmholtz	2.0m × 0.4m 0.40 m sep	2 kG(0.2 T)	10 kA	400 kW	1.2m × 0.2maxial × radial	24 wks
WE-RT-3000-3KG ★	RacetrackHelmholtz	3.0m × 1.5m 0.55 m sep	3 kG(0.3 T)	14.24 kA	800 kW	2.0m × 0.3maxial × radial	24 wks
WE-RT-4000-3KG	RacetrackHelmholtz	4.0m × 1.6m 0.70 m sep	3 kG(0.3 T)	18 kA	1.2 MW	2.8m × 0.35maxial × radial	28 wks
WE-RT-5000-4KG	RacetrackHelmholtz	5.0m × 1.8m 0.90 m sep	4 kG(0.4 T)	25 kA	2.5 MW	3.5m × 0.5maxial × radial	32 wks
WE-RT-6000-5KG	RacetrackHelmholtz	6.0m × 2.2m 1.10 m sep	5 kG(0.5 T)	35 kA	4.5 MW	4.2m × 0.6maxial × radial	36 wks
WE-HC-1500-4KG	CircularHelmholtz	Ø1500 mm 750 mm sep	4 kG(0.4 T)	18 kA	1.5 MW	Ø500 mmsphere	26 wks
WE-HC-2000-5KG	CircularHelmholtz	Ø2000 mm 1000 mm sep	5 kG(0.5 T)	28 kA	3.0 MW	Ø700 mmsphere	30 wks
WE-HC-3000-6KG	CircularHelmholtz	Ø3000 mm 1500 mm sep	6 kG(0.6 T)	45 kA	6.0 MW	Ø1000 mmsphere	34 wks
WE-HC-1000-6KG	CircularHelmholtz	Ø1000 mm 500 mm sep	6 kG(0.6 T)	20 kA	1.2 MW	Ø300 mmsphere	24 wks
WE-RT-3000-5KG	RacetrackHelmholtz	3.0m × 0.5m 0.55 m sep	5 kG(0.5 T)	24 kA	1.8 MW	2.0m × 0.3maxial × radial	26 wks
WE-HC-CUSTOM	Circular orRacetrack	Custom	0.1-6 kG	1-50 kA	10kW-6MW	Custom	TBD

★ WE-RT-3000-3KG: KJC reference design — Production-validated, FAT/SAT complete, active production use

Design Philosophy: Racetrack vs. Circular Geometry

RACETRACK HELMHOLTZ COILS provide extended axial field uniformity along one dimension—ideal for laser fusion target chambers, linear plasma devices, particle accelerators, and any application requiring uniform magnetic fields along an elongated axis. The racetrack geometry (elongated rectangular shape) delivers 2-4 meter uniformity zones that conventional circular Helmholtz pairs cannot achieve. Typical uniformity aspect ratio: 6:1 to 10:1 (axial length to radial diameter). Applications: laser fusion experiments (NIF-class systems), Z-pinch linear compression, magnetic nozzle thrusters, FRC formation in elongated chambers, beam transport in linear accelerators. CIRCULAR HELMHOLTZ COILS provide spherical field uniformity around a central point—optimal for compact spheromak formation, materials testing under uniform fields, sensor calibration, and applications requiring 3D uniform field access. The circular geometry offers easier mechanical construction, simpler field calculations, and omnidirectional experimental access through the coil bore. Typical uniformity: spherical volume with diameter ~40% of coil radius. Applications: spheromak plasma physics, dense plasma focus, magnetic mirror confinement, 3D materials characterization, magnetized target fusion with spherical compression. Both geometries use identical water-cooled aluminum hollow-conductor technology, IGBT buck converter power supplies, supercapacitor energy storage, and Portenta M4/Linux control platforms—enabling common spare parts inventory, maintenance procedures, and operational training across different coil configurations.

Common Construction Technology:

- Water-Cooled Hollow Conductor: All variants use hollow aluminum (or copper for high-current models) rectangular conductor with internal cooling channels. Water flows through the conductor cross-section, removing I²R heating directly at the source. Conductor cross-sections scale with current: 2-5 kA systems use 10×10 mm hollow conductor, 10-20 kA systems use 15×15 mm, 20-50 kA systems use 20×20 mm or larger. Flow rates: 5-20 liters/minute per coil depending on power dissipation and duty cycle.
- IGBT Buck Converter Power Supply: Supercapacitor-fed IGBT topology provides precise PWM current regulation with <1% ripple. IGBT modules paralleled to achieve required current (3 kA per module typical). PWM frequencies 100 Hz – 1 kHz balance control bandwidth against switching losses. Buck topology minimizes IGBT count compared to full-bridge designs. TDK Lambda AC-DC chargers (or equivalent) recharge supercapacitor banks during off-periods between experimental shots.
- Portenta M4/Linux Control Platform: All systems use identical control architecture—Portenta M4 dual-core ARM processor running Linux, GIGA touchscreen for local control, UDP Ethernet for remote sequencing. Programmable waveform generation (ramp/flat-top/ramp-down polynomials), real-time current/voltage monitoring, external enable interlocks, SCR crowbar overcurrent protection, fail-safe capacitor dump relays.

Woodruff Engineering Inc.

1003 Midtown Calle Central, Santa Fe, NM 87505, USA ·

woodruffeng.com sales@woodruffeng.com

Production datasheet reviewed & accepted requirements.

© 2026 Woodruff Engineering Inc. All rights reserved.

Software-enforced duty cycle limits prevent thermal damage. • Multi-Layer Protection: SCR crowbar at 1.3× nominal current per IGBT module, back-EMF diodes on outputs, OVP/OCP on all charger rails, fail-safe NC dump relay (auto-activates on power loss), thermal shutdown at 95°C IGBT junction, isolation testing $\geq 1 \text{ M}\Omega$ @ 500 V, ground continuity $< 1 \Omega$. • Modular Construction: Coils designed for field assembly from transportable sub-sections. Small systems ($\varnothing 300\text{-}1000 \text{ mm}$) ship as single units. Large systems ($> 2 \text{ m}$) ship as segments that bolt together on-site with precision alignment fixtures. All cooling manifolds use quick-disconnect fittings for rapid assembly/disassembly.

Scaling Relationships (Field, Current, Power):

Magnetic field scales with current and coil geometry: $B \propto N \times I / R$ (circular coils) $B \propto N \times I /$ (effective radius) (racetrack coils) Where N = number of turns, I = current, R = coil radius. For fixed turns (typical $N = 20\text{-}40$ for high-current systems), doubling the current doubles the field. Doubling the coil size (at constant current) halves the field—so large coils require higher currents to maintain field strength. Power dissipation scales as I^2R : • 2 kA system @ 0.01Ω : $(2000)^2 \times 0.01 = 40 \text{ kW}$ • 10 kA system @ 0.005Ω : $(10000)^2 \times 0.005 = 500 \text{ kW}$ • 25 kA system @ 0.003Ω : $(25000)^2 \times 0.003 = 1875 \text{ kW}$ Coil resistance decreases with size (longer length but larger conductor cross-section), but I^2 dominates—so high-current systems require megawatt-class cooling even at 5% duty cycle. Duty cycle determines average power: • 5% duty: 1 MW peak \rightarrow 50 kW average (18 s on / 9.5 min off) • 10% duty: 1 MW peak \rightarrow 100 kW average (36 s on / 5.5 min off) • 20% duty: 1 MW peak \rightarrow 200 kW average (requires enhanced cooling) Most systems operate at 5-10% duty cycle to balance experimental shot rate against thermal management complexity.

HIGH-CURRENT HELMHOLTZ COIL SYSTEMS

Technical Specification Form — Customer Requirements

Please complete all sections below. This information will be used to prepare a detailed quotation and ensure the coil system meets your requirements. If you have questions about any specification, contact us at sales@woodruffeng.com

CUSTOMER INFORMATION

Organization / Institution	
Contact Name	
Email Address	
Phone Number	
Shipping Address	

COIL CONFIGURATION

Coil Geometry Type (select one):

- Standard Circular Helmholtz Pair — Two identical circular coils in Helmholtz configuration
- Racetrack Helmholtz Pair — Elongated rectangular coils for extended axial uniformity
- Multiple-Axis Helmholtz System — Mutually perpendicular coil pairs for 3D field control
- Single Coil — One coil only (not a pair)
- Custom Geometry — Describe below

Standard Circular Helmholtz Pair Specifications:

Coil Inner Diameter (ID)		<i>mm or inches</i>
Coil Outer Diameter (OD)		<i>mm or inches</i>
Coil Axial Thickness		<i>mm or inches</i>

Woodruff Engineering Inc.

1003 Midtown Calle Central, Santa Fe, NM 87505, USA ·

woodruffeng.com sales@woodruffeng.com

Production datasheet reviewed & accepted requirements.

© 2026 Woodruff Engineering Inc. All rights reserved.

Coil Separation Distance		<i>mm (Helmholtz: separation = radius)</i>
---------------------------------	--	--

Racetrack / Custom Geometry Specifications:

Overall Length (long dimension)		<i>mm or meters</i>
--	--	---------------------

Overall Width (short dimension)		<i>mm or meters</i>
--	--	---------------------

Coil Depth (axial thickness)		<i>mm</i>
-------------------------------------	--	-----------

Coil Separation		<i>mm</i>
------------------------	--	-----------

Custom Geometry Details: _____

MAGNETIC FIELD REQUIREMENTS

Required Central Magnetic Field		<i>Gauss or Tesla or mT</i>
--	--	-----------------------------

Peak Field (if pulsed operation)		<i>Gauss or Tesla (leave blank if DC only)</i>
---	--	--

Field Uniformity Required		<i>±____% (typical: ±1%, ±3%, ±5%)</i>
----------------------------------	--	--

Uniformity Volume (spherical)		<i>mm diameter (volume where field meets uniformity spec)</i>
--------------------------------------	--	---

Uniformity Volume (cylindrical)		<i>mm length × mm diameter (for racetrack or elongated)</i>
--	--	---

Field Orientation:

- Vertical (perpendicular to floor)
- Horizontal (parallel to floor)
- No preference / other (specify): _____

Field Stability Requirements:

- No specific stability requirement (standard PWM or DC regulation)

- High stability: $\pm 0.1\%$ or better (requires precision current regulation)
- Ultra-high stability: $\pm 0.01\%$ or better (may require flux feedback control)

CURRENT AND POWER REQUIREMENTS

Operating Current per Coil		<i>Amps (A) or kiloamps (kA)</i>
Peak Current (if pulsed)		<i>Amps or kA (leave blank if DC only)</i>
Number of Turns per Coil		<i>turns (leave blank if unknown)</i>
Total Magnetomotive Force (MMF)		<i>Ampere-turns (if known)</i>

Operating Mode:

- Continuous DC Operation — Constant current, long-duration experiments
- Pulsed Operation — Short-duration pulses with off-time for cooling
- Quasi-Continuous — Extended pulses (minutes) with cooling between

Pulsed Operation Parameters (if applicable):

Pulse Duration (on-time)		<i>seconds or minutes</i>
Off-Time Between Pulses		<i>minutes</i>
Duty Cycle		<i>% (on-time / total cycle time)</i>
Pulse Repetition Rate		<i>pulses per hour or per day</i>

Estimated Power Requirements:

Available Electrical Power		<i>kW (facility power available for coil system)</i>
Input Voltage Available		<i>VAC (e.g., 120V, 208V, 480V 3-phase)</i>

COOLING REQUIREMENTS

Cooling Method:

- Air-Cooled — Natural convection (low-current, intermittent use)
- Forced Air-Cooled — Fans or blowers (moderate current, pulsed operation)

Woodruff Engineering Inc.

1003 Midtown Calle Central, Santa Fe, NM 87505, USA ·
woodruffeng.com sales@woodruffeng.com

Production datasheet reviewed & accepted requirements.
 © 2026 Woodruff Engineering Inc. All rights reserved.

- Water-Cooled — Internal water channels in copper conductor (high current, continuous or pulsed)
- Liquid Nitrogen (LN2) Cooled — Cryogenic operation for ultra-high fields
- Customer will specify — Describe requirements below

Water Cooling System (if applicable):

- Customer provides chiller — Specify cooling capacity available: _____ kW
- Woodruff Engineering to supply chiller — Quote separately
- Facility chilled water available — Specify inlet temperature: _____ °C, flow rate: _____ L/min

Maximum Allowable Coil Temperature		°C	<i>(operating temperature limit)</i>
Ambient Operating Temperature		°C	<i>(room temperature)</i>

CONDUCTOR AND CONSTRUCTION REQUIREMENTS

Conductor Type:

- Round Copper Wire — Standard magnet wire with enamel or polymer insulation
- Square / Rectangular Copper — Higher packing density, better thermal contact
- Hollow Copper Conductor — Internal water cooling channels for high-current applications
- Litz Wire — Reduced AC losses for high-frequency pulsed operation
- Aluminum Conductor — Lighter weight, lower cost (larger cross-section required)
- Other / Custom — Describe: _____

Insulation Class:

- Class A (105°C) — Standard for low-temperature applications
- Class F (155°C) — Common for moderate-temperature operation
- Class H (180°C) — High-temperature epoxy or Kapton insulation
- Class C (>180°C) — Ultra-high temperature (ceramic, mica)

Winding Configuration:

- Single-layer winding
- Multi-layer pancake winding

- Solenoid winding (helical)
- No preference (optimize for performance and cost)

Structural Requirements:

- Standard rigid coil former (fiberglass, G10, or phenolic)
- Vacuum-compatible construction (UHV $\leq 10^{-8}$ Torr)
- Non-magnetic materials only (stainless steel, aluminum, plastic)
- Minimal eddy current losses (segmented former, non-conductive materials)
- Removable / modular design for transport or maintenance

POWER SUPPLY AND CONTROL REQUIREMENTS

Power Supply Scope:

- Customer provides power supply — Coils only (specify PSU voltage/current below)
- Woodruff Engineering to supply power supply — Quote separately as turnkey system
- Existing power supply available — Integration with existing equipment

Power Supply Specifications (if WE to supply):

- Linear DC power supply — Low ripple, high stability for precision work
- Switching DC power supply — Compact, efficient for high-power applications
- IGBT-based PWM supply — Pulsed operation with programmable waveforms
- Bipolar supply — Reversible field direction (\pm current capability)

Required Output Voltage		<i>Volts (estimated coil voltage drop)</i>
Required Output Current		<i>Amps or kA</i>
Current Ripple Specification		<i>% (e.g., <1%, <0.1%)</i>

Control Interface:

- Manual control (front panel knobs/buttons)
- Analog control (0-10V setpoint input)
- Digital control (RS232, RS485, USB, Ethernet)
- LabVIEW integration required

EPICS / PLC / SCADA integration required (specify system: _____)

Remote Control Distance

meters (from PSU to control room)

Waveform Programming (for pulsed systems):

- Simple on/off switching
- Programmable ramp-up / flat-top / ramp-down profiles
- Arbitrary waveform generation (user-defined profiles)
- Synchronization with external trigger (e.g., laser firing, diagnostic timing)

PROTECTION AND SAFETY REQUIREMENTS

Standard Protection Features (typically included):

- ✓ Overcurrent protection (current limit or crowbar)
- ✓ Overvoltage protection
- ✓ Thermal protection (coil temperature monitoring)
- ✓ Emergency stop / E-stop integration
- ✓ Grounding and electrical isolation

Additional Safety Requirements:

- Personnel safety interlocks (door/gate monitoring, access control)
- Magnetic field warning indicators (field-on lamps, audible alarms)
- Fail-safe energy dump system (rapid discharge on fault)
- Coolant flow monitoring and low-flow shutdown
- Integration with facility safety systems (building fire alarm, interlock chains)
- Compliance with specific standards (specify): _____

INSTALLATION AND FACILITY REQUIREMENTS

Installation Location:

- Floor-mounted (medium to large coils)
- Overhead suspension / gantry-mounted

Woodruff Engineering Inc.

1003 Midtown Calle Central, Santa Fe, NM 87505, USA ·

woodruffeng.com sales@woodruffeng.com

Production datasheet reviewed & accepted requirements.

© 2026 Woodruff Engineering Inc. All rights reserved.

Vacuum chamber installation (outside and inside vacuum coils)

Custom mounting (describe below)

Available Floor Space		<i>meters × meters (footprint available)</i>
Floor Loading Capacity		<i>kg/m² or tonnes total</i>
Ceiling Height		<i>meters (for overhead crane access if needed)</i>

Handling and Transport:

Forklift access available

Overhead crane available (capacity: _____ tonnes)

Must be modular / disassembled for transport through doorways

Shipping to international location (specify country: _____)

Environmental Conditions:

Operating Temperature Range		<i>°C to °C</i>
Humidity Range		<i>% (typical lab: 20-80% RH)</i>

Clean room environment (specify class: _____)

Magnetic shielding required for surrounding equipment

Stray field limits outside coil system (specify): _____ Gauss @ _____ meters

APPLICATION DETAILS

Primary Application:

Calibration & Metrology — Precision magnetic field generation, sensor calibration

Fusion / Plasma Research — Plasma confinement, diagnostics, pulsed magnets

Particle Physics — Beam steering, focusing, detector magnets

Materials Research — High-field experiments, magneto-optical studies

Medical / MRI Research — Gradient coils, field shimming

Magnetic Levitation — Diamagnetic or electromagnetic suspension

Woodruff Engineering Inc.

1003 Midtown Calle Central, Santa Fe, NM 87505, USA ·

woodruffeng.com sales@woodruffeng.com

Production datasheet reviewed & accepted requirements.

© 2026 Woodruff Engineering Inc. All rights reserved.

- Industrial Testing — Non-destructive testing, electromagnetic forming
- Academic Research — University laboratory, teaching demonstrations
- Other (describe below)

Detailed Application Description:

(Brief description of experimental setup, research objectives, special requirements)

SCHEDULE AND BUDGET

Target Delivery Date		
Target Installation Date		
Budget Range (optional)		\$ _____ to \$ _____

Project Urgency:

- Standard lead time acceptable (8-24 weeks depending on complexity)
- Expedited delivery required (may incur premium pricing)
- Flexible timeline (optimize for cost)

Project Funding Status:

- Funded — ready to proceed with purchase order
- Budget estimate needed for funding approval
- Feasibility study / preliminary design
- Multi-year capital equipment acquisition

SPECIAL REQUIREMENTS AND SERVICES

Testing and Documentation:

- Factory Acceptance Testing (FAT) required
- Site Acceptance Testing (SAT) required

- Magnetic field mapping (measured B-field uniformity data)
- Inductance measurement and documentation
- Thermal testing and validation
- Complete test reports and certification
- As-built drawings and technical documentation
- Operation and maintenance manuals

Installation and Commissioning:

- Woodruff Engineering installation supervision required
- Woodruff Engineering commissioning support
- Operator training required (number of personnel: _____)
- Customer self-installation (documentation only)

Ongoing Support:

- Extended warranty or service contract
- Spare parts kit (specify critical components)
- Remote diagnostic support
- Annual maintenance / recalibration services

Additional Requirements or Notes:

SUBMISSION

Please email this completed form to: sales@woodruffeng.com

We will review your specifications and provide a detailed quotation within 5–10 business days. For complex custom systems or high-current pulsed applications, we may schedule a technical consultation to discuss detailed requirements, thermal management strategies, and facility integration.

Woodruff Engineering Inc.

1003 Midtown Calle Central, Santa Fe, NM 87505, USA ·
woodruffeng.com sales@woodruffeng.com

Production datasheet reviewed & accepted requirements.
© 2026 Woodruff Engineering Inc. All rights reserved.